

Reg. No.: _____

Name: _____

APJ ABDUL KALAM TECHNOLOGICAL UNIVERSITY

FIRST SEMESTER B.TECH DEGREE EXAMINATION, JANUARY 2017

Course Code: **BE101-04**Course Name: **INTRODUCTION TO ELECTRONICS ENGINEERING**

Max. Marks: 100

Duration: 3 Hours

PART A*Answer ALL questions. Each question carries 2 marks*

1. The sequence of colour bands in a resistor are: Green, Blue, Yellow and Silver. What is its resistance value? Write the colour code of 100Ω resistor with 5% tolerance.
2. Write the expression for capacitive reactance. Explain how capacitive reactance varies with frequency?
3. List any four circuits where you can find inductors.
4. What are the two mechanisms by which carriers move through a silicon crystal?
5. Define static and dynamic input resistance of a silicon diode. Write the typical values of the resistances.
6. Draw the V-I characteristics of a zener diode and mark its operating region.
7. What are the biasing conditions required for a transistor to work as a switch.
8. Derive the expression for collector current in common emitter configuration and explain each term in it.
9. What is thermal runaway and how does this affect a transistor?
10. List any four advantages of metal oxide semiconductor FET (MOSFET).
11. Draw and explain the structure of unijunction transistor (UJT).
12. What is pinch-off voltage? Draw the drain characteristics of a junction field effect transistor (JFET) and mark the pinch-off voltage.
13. Design a circuit to obtain the following transfer characteristics. Assume an ideal diode.

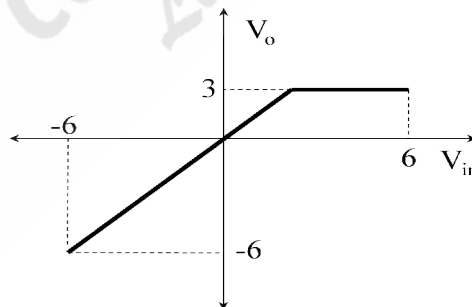

14. Define peak inverse voltage of a diode. Compare PIV of a centre tap rectifier and a bridge rectifier.

15. Draw the circuit diagram of a half-wave voltage doubler circuit. Draw the output wave form for the following input waveform.

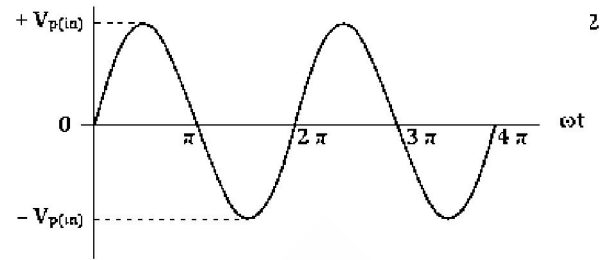

16. For the circuit shown below, find the output voltage across R_L and current through the zener diode.

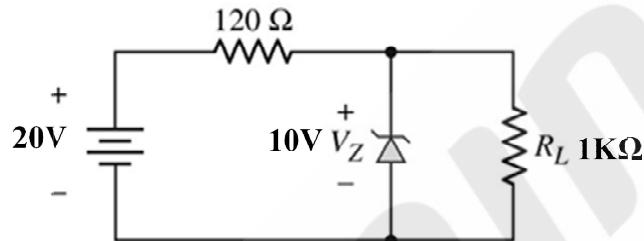

- 17. Define sensitivity and accuracy of a measuring instrument.
- 18. How can you measure the phase difference between two signals (both of them have same frequency) with a cathode ray oscilloscope (CRO) using Lissajous pattern.
- 19. What are the uses of function generator?
- 20. How can you test a PNP transistor using a multimeter? (Assume that the multimeter does not have a provision to measure h_{fe} or β)

PART B

Answer any 4 complete questions each having 10 marks

- 21.
 - a. Write a brief description about the constructional details of a wire wound resistor. (4)
 - b. How can you reduce the inductive effect in wire wound resistors? (2)
 - c. What are the advantages and disadvantages of solid state relays over mechanical relays? (4)
- 22.
 - a. Explain how a potential barrier is developed in a PN junction diode? (4)
 - b. A diode current is 0.6mA when applied voltage is 400mV and 20mA when the applied voltage is 500mV. Find 'n', the ideality factor. Assume $V_T = 26mV$. (3)
 - c. Explain the working principle of a varactor diode. (3)

- 23.
 - a. With reference to the following circuit, draw the DC load line and determine the Quiescent-point. (Given $V_{CC} = 10V$, $V_{BB} = 2V$, $R_C = 1K\Omega$,

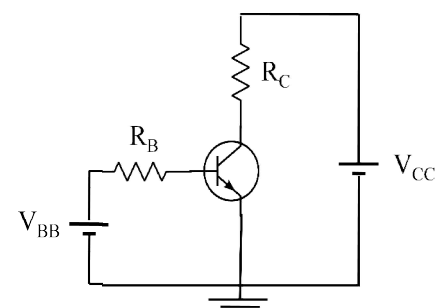

$$R_B=100K\Omega, \beta=200 \text{ and } V_{be} = 0.7V) \quad (5)$$

- b. Draw and explain the output characteristics of an NPN transistor in common-emitter (CE) configuration. (5)
- 24.
- a. What are the major differences between JFET and bipolar junction transistor (BJT). (5)
- b. Draw the structure of an n-channel JFET and explain its principle of operation. (5)
- 25.
- a. Draw the frequency response characteristics of an RC coupled amplifier and state the reasons for the reduction of gain at lower and higher frequencies. (4)
- b. Write a brief description about the constructional details of an Aluminium electrolytic capacitor. (4)
- c. Describe the working principle of LED. (2)

PART C

Answer any 2 complete questions each having 10 marks

- 26.
- a. Draw the circuit diagram of a centre-tapped full wave rectifier and explain its working. (5)
- b. What is ripple factor? Derive the expression for ripple factor of a full wave rectifier. (5)
- 27.
- a. Draw the circuit diagram of a double clipper, clipping at +5V and -5V. Explain its working and draw the input & output wave forms. Assume the knee voltage of the diode as 0.7V. (5)
- b. Explain the working of an analog electronic multimeter with the help of a schematic diagram. (5)
28. Draw the block diagram of a digital storage oscilloscope and explain the function of each block. (10)